

BUSH HOG®

GEARDRIVE HAY MOWERS



SERIES GHM 700, GHM 800, GHM 900
GHM 1800 & GHM 1900

Operator's Manual

ASSEMBLY ● OPERATION ● MAINTENANCE

CONGRATULATIONS!

You have invested in the best implement of its type on the market today.

The care you give your Bush Hog implement will greatly determine your satisfaction with its performance and its service life. We urge a careful study of this manual to provide you with a thorough understanding of your new implement before operating, as well as suggestions for operation and maintenance.

If your manual should become lost or destroyed, Bush Hog will be glad to provide you with a new copy. Order from Bush Hog, P. O. Box 1039, Selma, Alabama 36702-1039. Most of our manuals can also be downloaded from our website at www.bushhog.com.

As an authorized Bush Hog dealer, we stock genuine Bush Hog parts which are manufactured with the same precision and skill as our original equipment. Our trained service personnel are well informed on methods required to service Bush Hog equipment, and are ready and able to help you.

Should you require additional information or assistance, please contact us.

YOUR AUTHORIZED
BUSH HOG DEALER

BECAUSE BUSH HOG MAINTAINS AN ONGOING PROGRAM OF PRODUCT IMPROVEMENT, WE RESERVE THE RIGHT TO MAKE IMPROVEMENTS IN DESIGN OR CHANGES IN SPECIFICATIONS WITHOUT INCURRING ANY OBLIGATION TO INSTALL THEM ON UNITS PREVIOUSLY SOLD.

BECAUSE OF THE POSSIBILITY THAT SOME PHOTOGRAPHS IN THIS MANUAL WERE TAKEN OF PROTOTYPE MODELS, PRODUCTION MODELS MAY VARY IN SOME DETAIL. IN ADDITION, SOME PHOTOGRAPHS MAY SHOW SHIELDS REMOVED FOR PURPOSES OF CLARITY. **NEVER OPERATE** THIS IMPLEMENT WITHOUT ALL SHIELDS IN PLACE.

GHM HAY MOWER

TABLE OF CONTENTS

SECTION/PARA	PAGE	SECTION/PARA	PAGE
Warranty.....	3	IV. MAINTENANCE.....	12
Dealer Preparation Check List.....	4	4-1 Maintenance Check List	12
Safety Precautions.....	5	4-2 Lubrication	13
Federal Laws and Regulations	6	4-3 Blade Replacement	14
I. INTRODUCTION & DESCRIPTION	7	4-4 Belt Adjustment.....	14
1-1 Introduction	7	4-5 Belt Replacement	14
1-2 Description.....	7	4-6 Spindle Housing Removal and Reassembly	14
II. PREPARATION FOR USE.....	8	4-7 Cutter Bar Removal	15
III. OPERATING INSTRUCTIONS	10	4-8 Cutter Bar Installation	16
3-1 General Safety.....	10	4-9 Troubleshooting	17
3-2 Cutting Height.....	10	V. ASSEMBLY	19
3-3 Transporting.....	10	Safety Decals.....	21
3-4 Breakaway Latch	10	Torque Specifications.....	23
3-5 Operation	11		
3-6 Swath Board	11		
3-7 Cutter Bar Helper Spring Adjustment.....	12		
3-8 Unhitching From Tractor and Storage.....	12		

RETAIL CUSTOMER'S RESPONSIBILITY UNDER THE BUSH HOG WARRANTY

It is the Retail Customer and/or Operator's responsibility to read the Operator's Manual, to operate, lubricate, maintain and store the product in accordance with all instructions and safety procedures. Failure of the operator to read the Operator's Manual is a misuse of this equipment.

It is the Retail Customer and/or Operator's responsibility to inspect the product and to have any part(s) repaired or replaced when continued operation would cause damage or excessive wear to other parts or cause a safety hazard.

It is the Retail Customer's responsibility to deliver the product to the authorized Bush Hog Dealer, from whom he purchased it, for service or replacement of defective parts which are covered by warranty. Repairs to be submitted for warranty consideration must be made within forty-five (45) days of failure.

It is the Retail Customer's responsibility for any cost incurred by the Dealer for traveling to or hauling of the product for the purpose of performing a warranty obligation or inspection.

UNDERSTAND SIGNAL WORDS

DANGER: Indicates an imminently hazardous situation which, if not avoided, will result in death or serious injury. This signal word is to be limited to the most extreme situations.

WARNING: Indicates a potentially hazardous situation which, if not avoided, could result in death or serious injury.

CAUTION: Indicates a potentially hazardous situation which, if not avoided, may result in minor or moderate injury. It may also be used to alert against unsafe practices.

BUSH HOG® LIMITED WARRANTY



Bush Hog warrants to the original purchaser of any new Bush Hog equipment, purchased from an authorized Bush Hog dealer, that the equipment be free from defects in material and workmanship for a period of one (1) year for non-commercial, state, and municipalities' use and ninety (90) days for commercial use from date of retail sale. The obligation of Bush Hog to the purchaser under this warranty is limited to the repair or replacement of defective parts.

Replacement or repair parts installed in the equipment covered by this limited warranty are warranted for ninety (90) days from the date of purchase of such part or to the expiration of the applicable new equipment warranty period, whichever occurs later. Warranted parts shall be provided at no cost to the user at an authorized Bush Hog dealer during regular working hours. Bush Hog reserves the right to inspect any equipment or parts which are claimed to have been defective in material or workmanship.

DISCLAIMER OF IMPLIED WARRANTIES & CONSEQUENTIAL DAMAGES

Bush Hog's obligation under this limited warranty, to the extent allowed by law, is in lieu of all warranties, implied or expressed, **INCLUDING IMPLIED WARRANTIES OF MERCHANTABILITY AND FITNESS FOR A PARTICULAR PURPOSE** and any liability for incidental and consequential damages with respect to the sale or use of the items warranted. Such incidental and consequential damages shall include but not be limited to: transportation charges other than normal freight charges; cost of installation other than cost approved by Bush Hog; duty; taxes; charges for normal service or adjustment; loss of crops or any other loss of income; rental of substitute equipment, expenses due to loss, damage, detention or delay in the delivery of equipment or parts resulting from acts beyond the control of Bush Hog.

THIS LIMITED WARRANTY SHALL NOT APPLY:

1. To vendor items which carry their own warranties, such as engines, tires, and tubes.
2. If the unit has been subjected to misapplication, abuse, misuse, negligence, fire or other accident.
3. If parts not made or supplied by Bush Hog have been used in connection with the unit, if, in the sole judgement of Bush Hog such use affects its performance, stability or reliability.
4. If the unit has been altered or repaired outside of an authorized Bush Hog dealership in a manner which, in the sole judgement of Bush Hog, affects its performance, stability or reliability.
5. To normal maintenance service and normal replacement items such as gearbox lubricant, hydraulic fluid, worn blades, or to normal deterioration of such things as belts and exterior finish due to use or exposure.
6. To expendable or wear items such as teeth, chains, sprockets, belts, springs and any other items that in the company's sole judgement is a wear item.

NO EMPLOYEE OR REPRESENTATIVE OF BUSH HOG IS AUTHORIZED TO CHANGE THIS LIMITED WARRANTY IN ANY WAY OR GRANT ANY OTHER WARRANTY UNLESS SUCH CHANGE IS MADE IN WRITING AND SIGNED BY BUSH HOG'S SERVICE MANAGER, POST OFFICE BOX 1039, SELMA, ALABAMA 36702-1039.



Record the model number, serial number and date purchased. This information will be helpful to your dealer if parts or service are required.

MODEL NUMBER _____

MAKE CERTAIN THE WARRANTY REGISTRATION CARD HAS BEEN FILED WITH BUSH HOG/
SELMA, ALABAMA

SERIAL NUMBER _____

DATE OF RETAIL SALE _____

DEALER PREPARATION CHECK LIST

GHM HAY MOWER

BEFORE DELIVERING MACHINE — The following check list should be completed.
Use the Operator's Manual as a guide.

- 1. Assembly completed.
- 2. Gearbox filled with oil.
- 3. All fittings lubricated.
- 4. All shields in place and in good condition.
- 5. All fasteners torqued to specifications given in Torque Chart.
- 6. All decals in place and readable. (See decal page.)
- 7. Overall condition good (i.e. paint, welds)
- 8. Operators manual has been delivered to owner and he has been instructed on the safe and proper use of the mower.

Dealer's Signature _____

Purchaser's Signature _____

THIS CHECKLIST TO REMAIN IN OWNER'S MANUAL

It is the responsibility of the dealer to complete the procedures listed above before delivery of this implement to the customer.

IMPORTANT SAFETY PRECAUTIONS

This symbol is used to call attention to safety precautions that should be followed by the operator to avoid accidents. When you see this symbol, carefully read the message that follows and heed its advice. Failure to comply with safety precautions could result in serious bodily injury.



In addition to the design and configuration of equipment, hazard control and accident prevention are dependent upon the awareness, concern, prudence and proper training of personnel in the operation, transport, maintenance and storage of equipment. Lack of attention to safety can result in accident, personal injury, reduction of efficiency and worst of all—loss of life. Watch for safety hazards and correct deficiencies promptly. Use the following safety precautions as a general guide to safe operations when using this machine. Additional safety precautions are used throughout this manual for specific operating and maintenance procedures. Read this manual and review the safety precautions often until you know the limitations.

1. Read the Operator's Manual. Failure to read the Operator's Manual is considered a misuse of this equipment.
2. Become familiar with all the machine's controls and all the caution, warning and danger decals affixed to the machine before attempting to start or operate.
3. Before starting or operating the machine, make a walk around inspection and check for obvious defects such as loose mounting bolts and damaged components. Correct any deficiency before starting.
4. Do not allow children to operate the mower. Do not allow adults to operate it without proper instruction.
5. Do not carry passengers.
6. Keep the area of operation clear of all persons, particularly small children and pets. The operator should cease mowing whenever anyone comes within the operating area.
7. Clear the work area of objects which might be picked up and thrown.
8. Use a piece of cardboard or wood rather than hands to search for hydraulic leaks. Escaping hydraulic oil under pressure can penetrate skin. If fluid is injected into the skin, it must be surgically removed within a few hours by a doctor familiar with this form of injury or gangrene may result.
9. Do not operate without all guards and shields in place and in good condition.
10. Stop PTO, lower implement to ground, place tractor transmission in neutral or park, set parking brake, stop tractor engine, remove ignition key and wait for all motion to completely stop before leaving the tractor.
11. Keep hands and feet away from blades.
12. This mower is not to be operated in any area where people may be present unless all sides of the unit are enclosed by a curtain guard that is in good repair.
13. Wear personal protective equipment such as, but not limited to, protection for eyes, ears, feet, hands and head when operating or repairing the equipment. Do not wear loose clothing or jewelry that may catch on equipment moving parts.
14. When performing adjustments or maintenance on the mower, first lower it to the ground or block it securely at a workable height.
15. Never stand between tractor and mower while tractor is being backed to the cutter hitch.
16. Reduce speed when transporting mower to avoid bouncing and momentary loss of steering.
17. Use tractor flashing warning lights, day or night, when transporting mower on road or highways unless prohibited by law.
18. Pin transport lock to retain cutter bar in transport position.
19. Lower mower to ground before unhitching from tractor.
20. In the event that someone other than yourself will operate this equipment we firmly suggest that all SAFETY references be discussed prior to operation.
21. It is recommended that tractor be equipped with Rollover Protective System (ROPS) enclosed cab, and a seat belt.

IMPORTANT FEDERAL LAWS AND REGULATIONS* CONCERNING EMPLOYERS, EMPLOYEES AND OPERATIONS.

*(This section is intended to explain in broad terms the concept and effect of the following federal laws and regulations. It is not intended as a legal interpretation of the laws and should not be considered as such).

U.S. Public Law 91-596 (The Williams-Steiger Occupational and Health Act of 1970) OSHA

This Act Seeks:

"...to assure so far as possible every working man and woman in the nation safe and healthful working conditions and to preserve our human resources..."

DUTIES

Sec. 5 (a) Each employer—

- (1) shall furnish to each of his employees employment and a place of employment which are free from recognized hazards that are causing or are likely to cause death or serious physical harm to his employees;
- (2) shall comply with occupational safety and health standards promulgated under this Act.
 - (b) Each employee shall comply with occupational safety and health standards and all rules, regulations and orders issued pursuant to this Act which are applicable to his own actions and conduct.

OSHA Regulations

Current OSHA regulations state in part: "At the time of initial assignment and at least annually thereafter, the employer shall instruct every employee in the safe operation and servicing of all equipment with which the employee is, or will be involved." These will include (but are not limited to) instructions to:

Keep all guards in place when the machine is in operation;

Permit no riders on equipment;

Stop engine, disconnect the power source, and wait for all machine movement to stop before servicing, adjusting, cleaning or unclogging the equipment, except where the machine must be running to be properly serviced or maintained, in which case the employer shall instruct employees as to all steps and procedures which are necessary to safely service or maintain the equipment.

Make sure everyone is clear of machinery before starting the engine, engaging power, or operating the machine.

EMPLOYEE TRACTOR OPERATING INSTRUCTIONS:

1. Securely fasten your seat belt if the tractor has a ROPS.
2. Where possible, avoid operating the tractor near ditches, embankments, and holes.
3. Reduce speed when turning, crossing slopes, and on rough, slick, or muddy surfaces.
4. Stay off slopes too steep for safe operation.
5. Watch where you are going, especially at row ends, on roads, and around trees.
6. Do not permit others to ride.
7. Operate the tractor smoothly - no jerky turns, starts, or stops.
8. Hitch only to the drawbar and hitch points recommended by tractor manufacturers.
9. When tractor is stopped, set brakes securely and use park lock if available.

Child Labor Under 16 Years Old

Some regulations specify that no one under the age of 16 may operate power machinery. It is your responsibility to know what these regulations are in your own area or situation. (Refer to U.S. Dept. of Labor, Employment Standard Administration, Wage & Home Division, Child Labor Bulletin #102.)

SECTION 1

INTRODUCTION AND DESCRIPTION

1-1 INTRODUCTION

We are pleased to have you as a Bush Hog customer. Your GHM hay mower has been carefully designed to give maximum service with minimum down time. This manual is provided to give you the necessary operating and maintenance instructions for keeping your mower in top operating condition. Please read this manual thoroughly. Understand what each control is for and how to use it. Observe all safety precautions decaled on the machine and noted throughout the manual for safe operation of implement. If any assistance or additional information is needed, contact your authorized Bush Hog dealer.

NOTE

All references made to right, left, front, rear, top or bottom is as viewed facing the direction of forward travel with implement properly attached to tractor.

1-2 DESCRIPTION

The GHM (Figure 1-1) is intended for cutting hay and grass in a clean maintained area. A breakaway mechanism built into the three point hitch allows cutter bar to pivot back if a stationary object is hit. The cutter bar consists of individual spindle assemblies driven from the main gearbox by a gear train. An optional overrunning clutch is available to allow "coast down" of blades when PTO is disengaged.

Figure 1-1 GHM Major Components (Safety Curtain Removed To Show Details Only)
HM 900 Shown

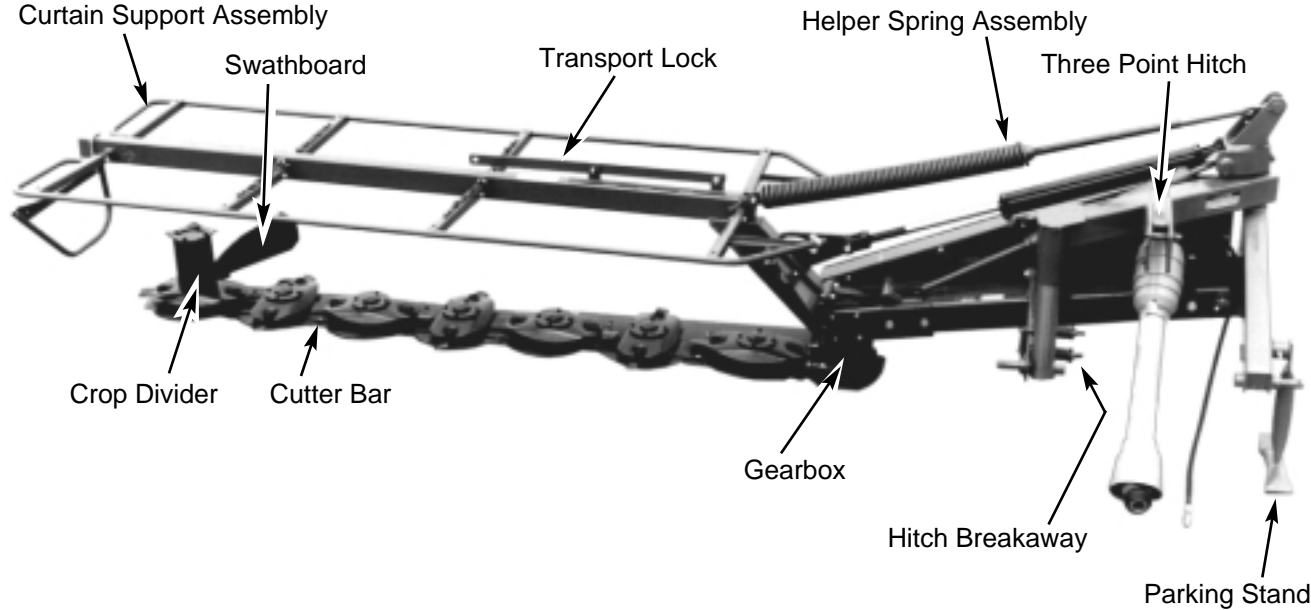

SECTION II PREPARATION FOR USE

⚠ WARNING ⚠

TO AVOID SERIOUS INJURY OR DEATH NEVER STAND BETWEEN TRACTOR AND MOWER WHILE TRACTOR IS BEING BACKED TO HITCH.

⚠ WARNING ⚠

TO AVOID SERIOUS INJURY OR DEATH ADDITIONAL TRACTOR FRONT BALLAST MAY BE NEEDED FOR STABLE OPERATION AND TRANSPORT OF MOWER. SEE TRACTOR OPERATOR'S MANUAL FOR RECOMMENDED WEIGHTS.

During mower operations, the right tractor tire should run on stubble between the cut and uncut crop. As shown in Figure 2-1, tractors with smaller/larger wheel tread widths require the mower to be mounted differently to achieve this.

A. Position mower hitch pins and attach mower to tractor according to the illustration in Figure 2-1 that is closest to your situation. Hitch pins are reversible to accommodate Cat. I or Cat. II hitches. On larger tractors it may also be necessary to move the right wheel inward. The STANDARD configuration will work on tractors with a maximum dimension of 46" from centerline to outside of right tire.

NOTE

If tractor is equipped with a Cat. II quick hitch, mower must have optional bushings installed on upper and lower lift pins as shown in Figure 2-2. Lower lift pins must be attached to the mower as shown in the STANDARD configuration of Figure 2-1.

B. Connect and/or adjust stabilizer bars, sway blocks, sway chains, or equivalent to prevent lateral movement of lift arms. Refer to tractor operator's manual.

C. Connect hydraulic hose to tractor remote hydraulic outlet.

Figure 2-2

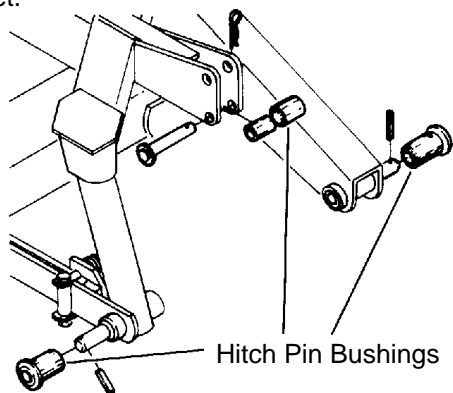
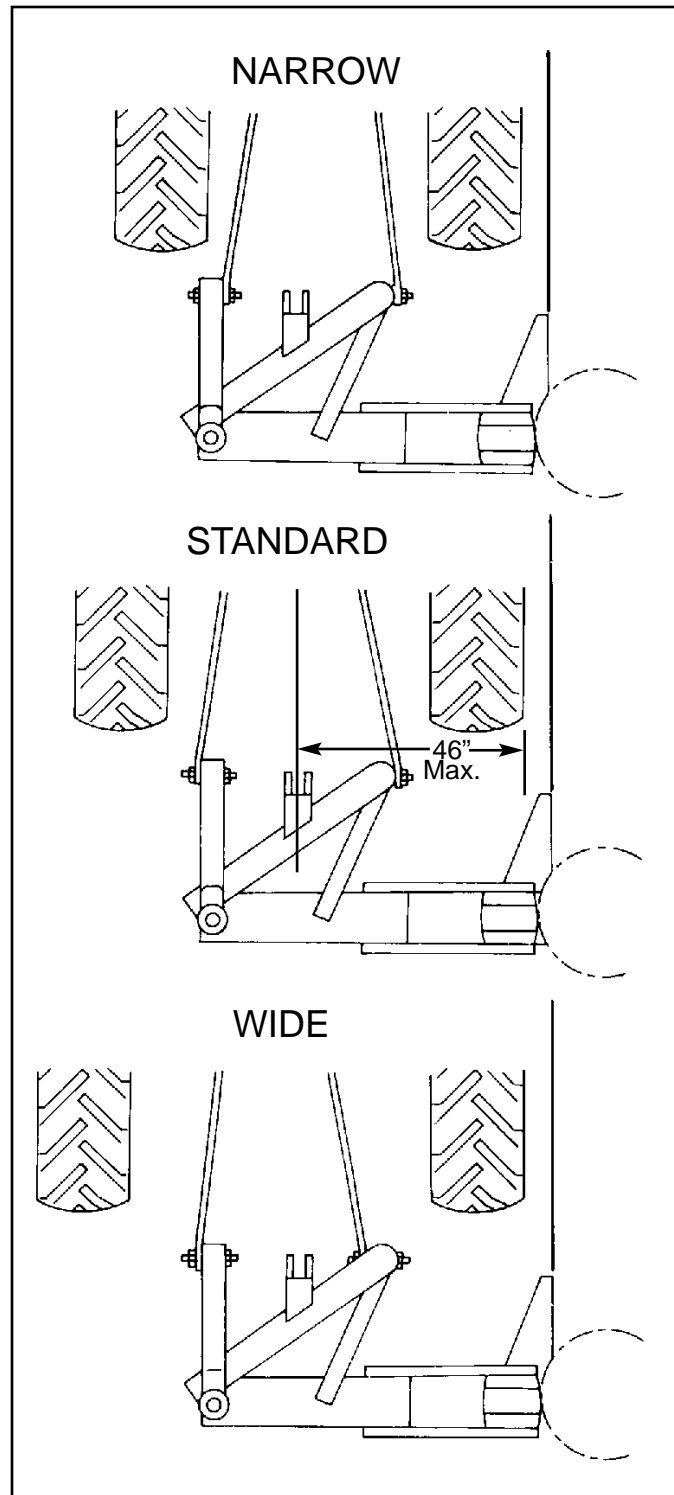
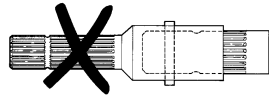

Figure 2-1 Hitch Adjustments



D. Attach PTO driveline to tractor 540 rpm or 1000 rpm PTO shaft. Make certain driveline is securely connected at both ends. Attach PTO driveline shield safety chain on both the implement and tractor ends. (Figure 2-3)



CAUTION

DO NOT USE A PTO SHAFT ADAPTER WITH THIS IMPLEMENT. USE OF A PTO SHAFT ADAPTER WILL VOID ALL WARRANTY CONSIDERATIONS.

E. Pin parking stand in work position. (Figure 2-4)

F. Adjust tractor lower lift arms so vertical main frame is perpendicular to the ground as shown in Figure 2-5.

G. Set tractor 3-point hitch depth control or install the optional check chain assembly to stop with the horizontal main frame pivot approximately 20 inches from the ground. (Figure 2-4)

Figure 2-3

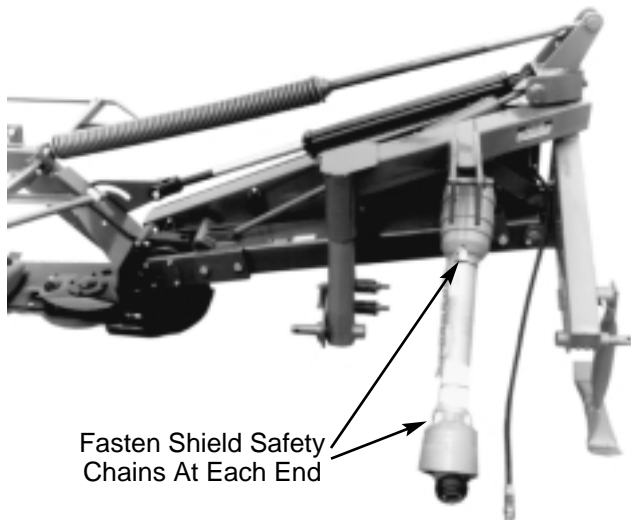
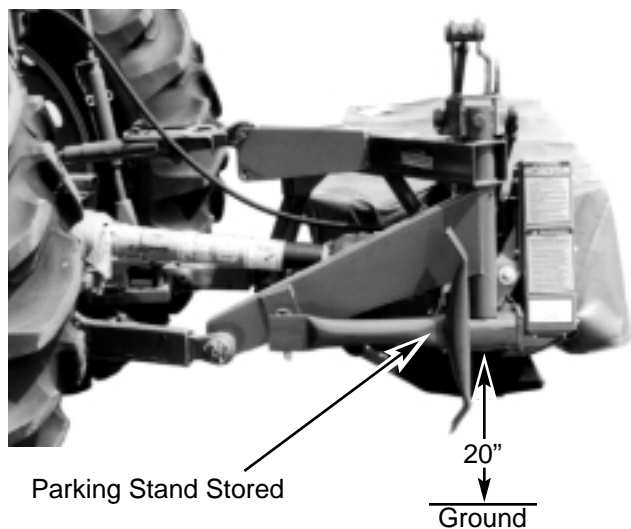

Figure 2-4



H. Check to be certain all persons are clear of cutter bar.

I. Raise mower using tractor 3-point lift. Raise cutter bar to transport position. When cylinder "bottoms out" hold valve open an additional 3-5 seconds to purge air from system.

J. Pin transport lock to retain cutter bar in the transport position. (Figure 2-6)

Figure 2-5

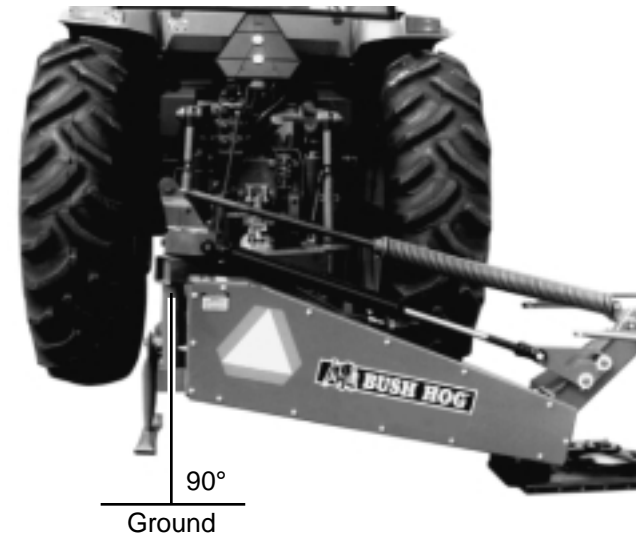

Figure 2-6 Transport Lock



SECTION III OPERATING INSTRUCTIONS

3-1 GENERAL SAFETY

Only qualified people familiar with this operator's manual should operate this machine. Operator should wear hard hat, safety glasses and safety shoes. The operator should read, understand and practice all safety messages shown on the caution, warning and danger decals affixed to the mower to avoid serious injury or death. It is recommended that tractor be equipped with Rollover Protective System (ROPS) and a seat belt be used. Before beginning operation, clear work area of any objects that may be picked up and thrown. Check for ditches, stumps, holes or other obstacles that could upset tractor or damage mower. Always turn off tractor engine, set parking brake, lower mower to ground and allow blades to come to a complete stop before leaving tractor operator's seat.

3-2 CUTTING HEIGHT

Cutting height is controlled by tilting the cutter bar forward or rearward. Shorten the 3-point hitch top link to tilt cutter bar forward and decrease cutting height or lengthen top link to increase cutting height. Recommended cutting heights are approximately 1" to 2-1/2".

Figure 3-1

3-Point Hitch Top Link - Cutting Height Adjustment



3-3 TRANSPORTING



TO AVOID SERIOUS INJURY OR DEATH, DO NOT ALLOW CUTTER BAR TO CONTACT ELECTRICAL WIRES. USE CARE WHEN PASSING BENEATH OVERHEAD OBSTRUCTIONS.

Raise mower off ground using 3-point hitch. Fully raise cutter bar and pin transport lock in the transport position. (Figure 2-6) Place parking stand in the work position as shown in Figure 2-4. Make certain slow moving vehicle (SMV) sign mounted on rear shield is clean and in good condition. When transported on roads or highways, day or night, use tractor flashing warning lights unless prohibited by law. Do not exceed 15 mph.

3-4 BREAKAWAY LATCH

IMPORTANT

During operation the cutter bar should operate at 90° to the path of travel. The lead angle of the cutter bar may be adjusted by varying the mounting position of the breakaway assembly. The combination of holes and adjustment plate allow up to five different positions. (Figure 3-2)

The breakaway latch, shown in Figure 3-2, allows the cutter bar to swing rearward if an obstruction is hit. If the latch releases, stop tractor and disengage PTO immediately. Thoroughly check cutter bar components for damage.

Figure 3-2 Breakaway Latch

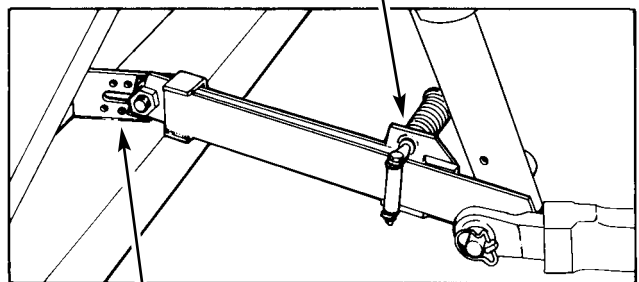

Lead Adjustment Plate

IMPORTANT

FAILURE TO STOP IMMEDIATELY AFTER BREAKAWAY LATCH TRIPS CAN CAUSE DAMAGE TO MOWER

To reset breakaway latch, slowly back up tractor with PTO disengaged and without raising cutter bar. The pressure of the cutter bar on the ground should be enough to reset latch.

Breakaway pressure is regulated by the tension of the latch springs (Figure 3-3). Spring length as shipped from the factory is 4-1/8" and is satisfactory for most conditions. Breakaway pressure can be increased by turning spring retaining nuts clockwise or decreased by turning counterclockwise. **DO NOT COLLAPSE SPRING TO LESS THAN 3-3/4" OR SPRING WILL BECOME SOLID BEFORE LATCH CAN TRIP.**

Figure 3-3

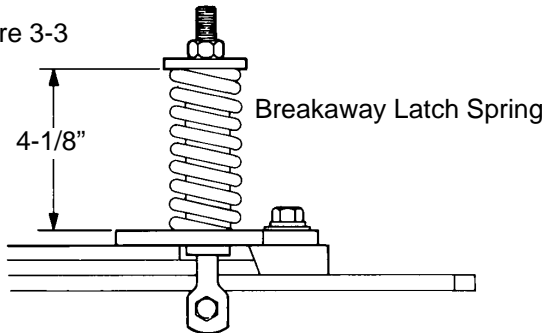

3-5 OPERATION

- A. Perform BEFORE EACH USE maintenance listed in paragraph 4-1.
- B. Pin parking stand and transport latch in the work position.
- C. Start tractor. Set tractor 3-point hitch depth control or install the optional check chain assembly to stop with the horizontal main frame pivot approximately 20" from the ground. (Figure 2-4) Check chain retainers should be installed onto tractor rear casting using top link pin.
- D. Lower cutter bar parallel to ground. Lower 3-point hitch to work position. Place control valve for cutter bar cylinder in "float" position.



DANGER

TO AVOID SERIOUS INJURY OR DEATH: STAY CLEAR OF ROTATING DRIVELINE. DO NOT OPERATE WITHOUT DRIVELINE SHIELDS IN PLACE AND IN GOOD CONDITION.



DANGER

TO AVOID SERIOUS INJURY OR DEATH: STAND CLEAR OF ROTATING MOWER BLADES UNTIL ALL MOTION HAS STOPPED. TO AVOID ACCIDENTAL FALL FROM TRACTOR AND POSSIBLE INJURY FROM MOWER, IT IS RECOMMENDED THAT TRACTOR BE EQUIPPED WITH ROLLOVER PROTECTIVE SYSTEM (ROPS) AND THAT A SEAT BELT BE USED FOR ALL MOWING OPERATIONS.

E. With tractor at idle speed, engage PTO drive. Set tractor throttle for 540 PTO rpm for models GHM 700, GHM 800, and GHM 900 and 1000 PTO rpm for models GHM 1800 and GHM 1900.

F. Place tractor in a gear that will give proper speed for terrain and crop conditions, then begin mowing. Tractor forward speed should be controlled by gear selection, not engine speed. For maximum efficiency, forward speed should allow mower to maintain a constant maximum blade speed.

If tractor engine stalls, do not slip tractor clutch to allow engine to regain speed as this will exert tremendous strain on the driveline. When stalling occurs, disengage PTO drive, move to a cut area, set tractor throttle at idle, then re-engage PTO drive. If stalling continues, use lower gear.



DANGER

TO AVOID SERIOUS INJURY OR DEATH FROM THROWN OBJECTS: DO NOT OPERATE WITH CURTAIN GUARD REMOVED. DO NOT OPERATE WITHOUT CURTAIN GUARD IN GOOD CONDITION OR REPAIR.

3-6 SWATH BOARD

The swath board is manufactured in the correct position for most efficient operation. However, some conditions may require that the swath board be removed. To do this remove the bolt at the spring assembly and remove the complete assembly.

Figure 3-4 Swath Board Assembly

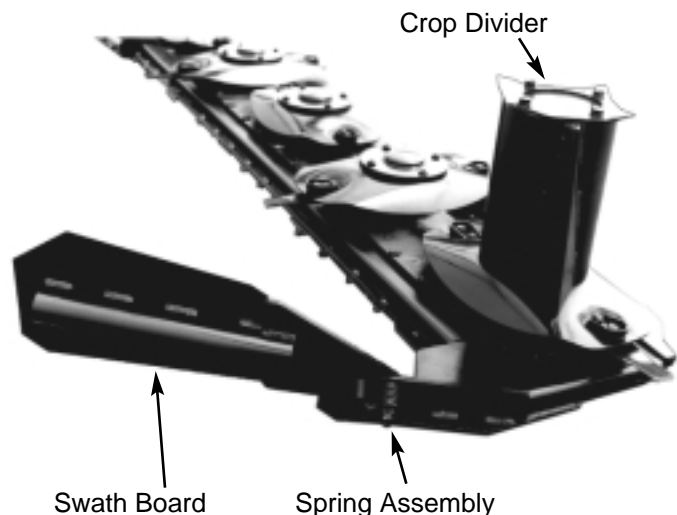

3-7 CUTTER BAR HELPER SPRING ADJUSTMENT (9' MODELS ONLY)

The 9' models are equipped with a helper spring assembly to transfer cutter bar weight from the outer end of the cutter bar back to the frame assembly. The recommended minimum adjustment measurement is 5-1/2" from under the bolt head to the end of the rod weldment nut. (Figure 3-5) To transfer more weight, shorten the measurement. To transfer less weight, lengthen the measurement. Be advised, the shorter the measurement, the less the outer end of the cutter bar can reach down.

3-8 UNHITCHING FROM TRACTOR AND STORAGE

To prevent rust, always clean all debris from mower after use. Store in a clean, dry place preferably with a hard, level floor. Clean and paint any areas where paint is missing. Apply a light coat of grease to cylinder rod..

Unhitch mower as follows:

- A. Pin parking stand in the down position as shown in Figure 3-6.
- B. Unfold cutter bar and lower to ground.
- C. Lower 3-point hitch to rest on parking stand. Make certain all pressure is relieved from cutter bar cylinder.
- D. Disconnect PTO driveline, hydraulic hose, and 3-point links.



WARNING

TO AVOID SERIOUS INJURY OR DEATH: ALWAYS STORE MOWER WITH THE CUTTER BAR IN THE UNFOLDED (HORIZONTAL) POSITION.

Figure 3-5 Helper Spring Assembly



Figure 3-6 Parking Stand



SECTION IV MAINTENANCE

4-1 MAINTENANCE CHECK LIST

Perform scheduled maintenance as outlined below. Lower implement to ground, turn off tractor, and set parking brake before doing maintenance inspections or work. Some checks may require raising machine off ground and supporting with blocks. All bolts should be torqued as indicated in torque at end of manual unless otherwise indicated.



WARNING

THE MOWER CAN FALL FROM HYDRAULIC SYSTEM FAILURE. TO AVOID SERIOUS INJURY OR DEATH, SECURELY SUPPORT MOWER BEFORE WORKING UNDERNEATH.

BEFORE EACH USE

1. Perform LUBRICATION per paragraph 4-2.
2. Check blades and spindles to be sure that no foreign objects such as wire or steel strapping bands are wrapped around them.
3. Inspect blades for wear. Replace if necessary per paragraph 4-3. **Always replace both blades with two blades equal in weight.** Use only genuine Bush Hog replacement parts.
4. **Check blade bolts for tightness. Tighten to 50 ft./lbs.**
5. Make certain all shields are in place and in good condition. Repair or replace any missing or damaged shields.
6. Check tractor tire air pressure. Refer to tractor operator's manual.
7. During operation, listen for abnormal sounds which might indicate loose parts, damaged bearings, or other damage. Correct any deficiency before continuing operation.

AFTER EACH USE

1. Clean all debris from machine. Replace any missing or illegible decals.
2. Inspect mower for worn or damaged components. Repair or replace before next use. Any replacement components installed during repair shall include the components current safety decals specified by the manufacturer to be affixed to the component.
3. Store mower in a dry place.

4-2 LUBRICATION (Figures 4-1a, b, c, d)

NOTE

The multi-purpose grease referenced in this section is an NLGI Grade 2 type grease.

8 HOURS

1. Driveline Universal Joints - Apply multi-purpose grease with grease gun.
2. Driveline Guard - Apply 2-3 shots of multipurpose grease with grease gun to plastic fitting.
3. Cutter Bar Pivot - Apply multi-purpose grease with grease gun. (2 fittings)

20 HOURS

4. **Main Gearbox - Add EP80W-90 gear oil, if necessary, to bring oil level to mark on dip stick.**
5. **Gear Bar Assembly - Fold mower into the transport position and fasten transport lock. Clean any grime and filth from around the fill/level plug. Add EP80W-90 gear oil, if necessary, to bring oil level up to the fill hole.**
6. Overrunning Clutch - Apply multi-purpose grease with grease gun.
7. Driveline - Disconnect PTO driveline, pull the two sections apart, apply thin coat of multi-purpose grease to outside of inner (male) section. Reassemble sections and install. Pull each section to be sure driveline and shields are securely connected. Make certain PTO shielding is in good condition.
8. Mast Pivot - Apply multi-purpose grease with grease gun. (Figure 4-4)

Figure 4-1c

Overrunning Clutch

(6) 20 Hours

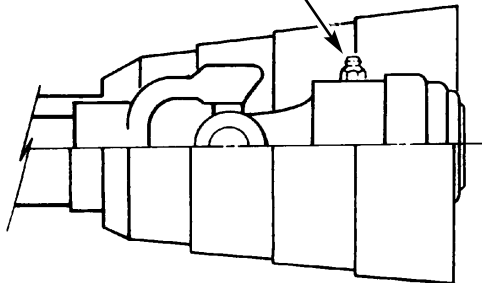
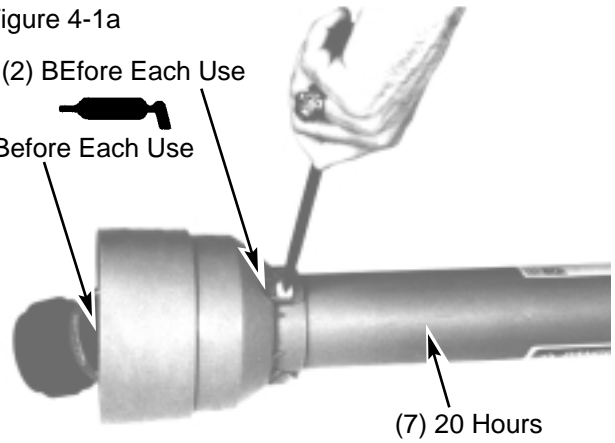

Figure 4-1a

(2) BEfore Each Use
(1) Before Each Use



(7) 20 Hours

To Remove Yoke Shield: Turn all three tabs 1/4 turn with screwdriver and remove tabs. Slide cover and plastic tube back.

Figure 4-1b

(4) 20 Hours

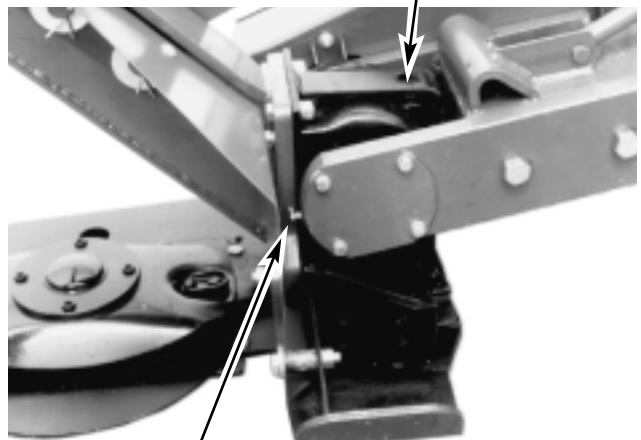

(3) Before Each Use

Figure 4-1d

(5) 20 Hours - Gear Bar Lube



4-3 BLADE REPLACEMENT

The disc mower blades each have two cutting edges. When one edge becomes dull or damaged, remove the bolt and turn the blade over, Nuts can be re-used if not damaged. If both cutting edges of the blade have been damaged, the blades must be replaced. Always replace both blades on a spindle to retain balance. **When replacing blades, the attaching bolt and nut should also be replaced.** Use only genuine Bush Hog replacement parts. (Figure 4-2)

Figure 4-2

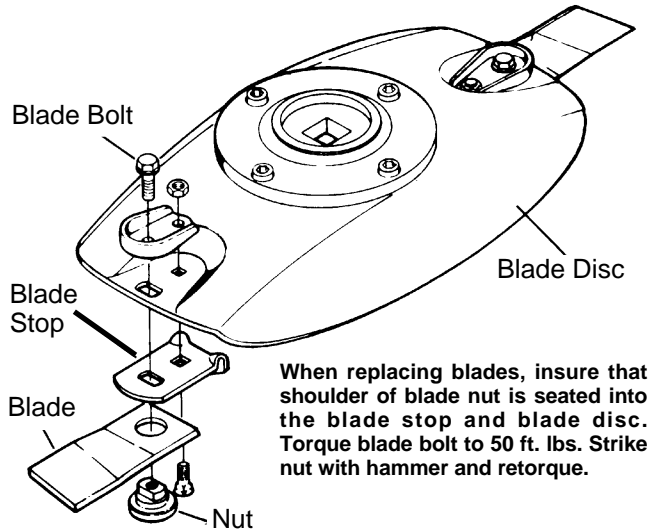

4-4 BELT ADJUSTMENT

Belt tension should be checked after first 2 hours of operation and thereafter every 40 hours to get maximum life from drive belts and best performance from mower. To check adjustment, push upward through hole in bottom of belt shield with 10 lbs. of force. Belt should deflect approximately 1/2 inch (Figure 4-3). To increase tension, loosen jackshaft assembly pivot bolt, (Figure 4-8), loosen jam nut, and turn adjusting nut (Figure 4-4) clockwise. Tighten pivot bolt and jam nut.

Figure 4-3

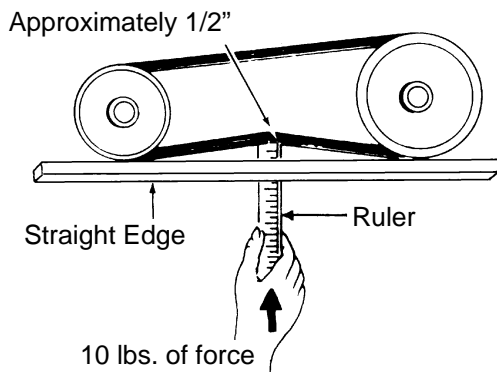

4-5 BELT REPLACEMENT

Replacement belts are sold in matched sets. To maintain an equal amount of tension on each belt, replace all belts at same time. Use only genuine Bush Hog replacement parts. Replace as follows:

- Remove belt shield cover.
- Loosen jackshaft assembly pivot bolt, loosen jamnut, and turn adjusting nut (Figure 4-4) counterclockwise to relieve belt tension.
- Remove belts.
- Install new matched set of belts.
- Tighten adjusting nut until belts deflect 1/2" with 10 lbs. of force applied (Figure 4-3). **Rotate belt pulleys 6 complete revolutions to seat the belts into the pulleys.** Tighten adjusting nut a second time until belts deflect 1/2" with 10 lbs. of force applied. Tighten jam nut on adjusting nut and tighten assembly pivot bolt.
- Install belt shield cover.

Figure 4-4 (8) Mast Pivot Grease Fitting

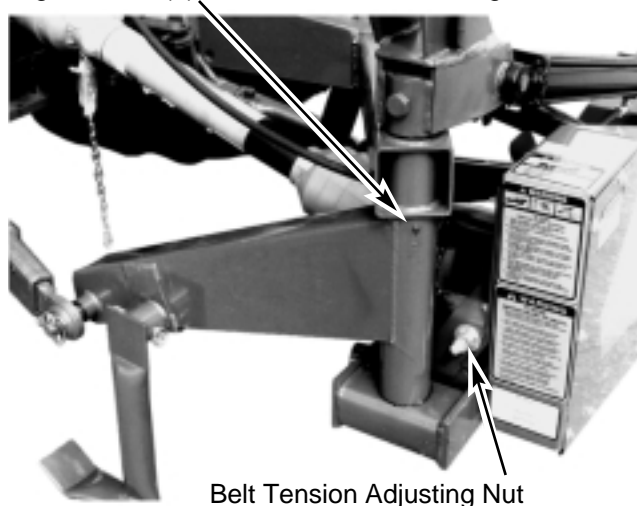

4-6 SPINDLE HOUSING REMOVAL AND REASSEMBLY

- Lower cutter bar to rest on a flat surface that will support the entire length. (Figure 4-5)
- Remove the cap and the blade disc assembly retaining nut on desired blade disc assembly. The outer gear housing assembly has the crop divider assembled to the blade disc assembly. The cap for the crop divider must be removed to provide access to the retaining nut.

STANDARD CROP DIVIDER - Detach the cap and cutter by removing the four (4) capscrews attaching the cap to the crop divider. (Figure 4-6)

OPTIONAL CROP DIVIDER - Remove cap by loosening jam nut, turn threaded rod counterclockwise so cap moves down on threaded rod approximately 1-1/2" tilt cap sideways and remove out the top of crop divider. (Figure 4-7)

Figure 4-5

(Curtain Removed To Show Details Only)

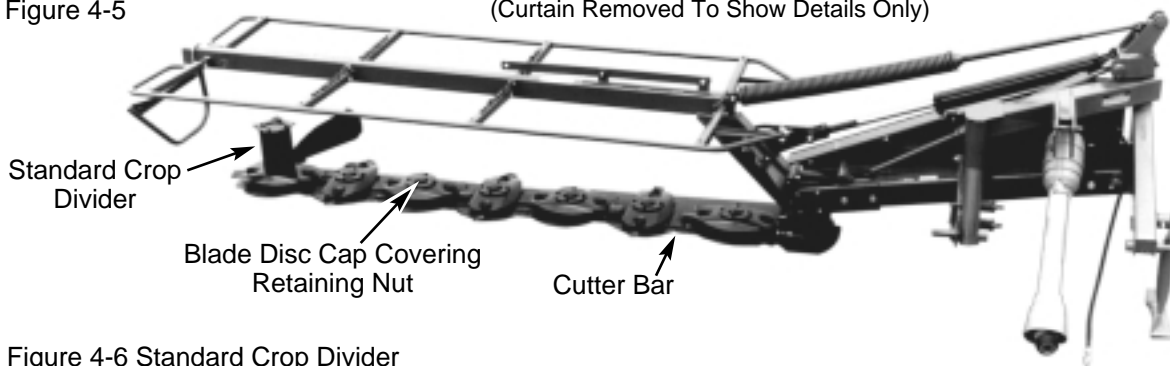

Figure 4-6 Standard Crop Divider

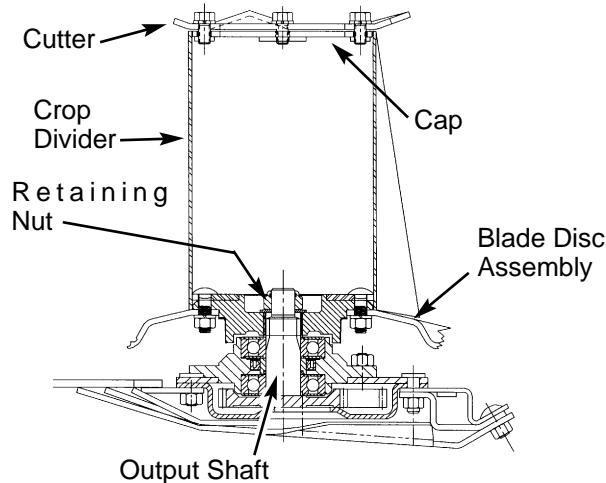
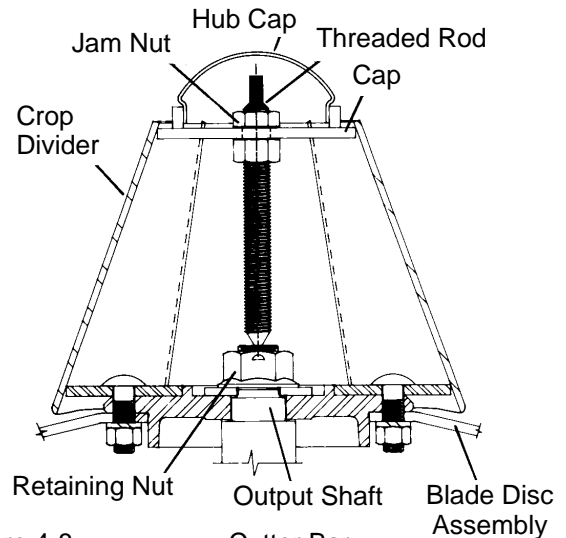

Figure 4-7 Optional Crop Divider



The blade disc assembly is now ready to be removed from the cutter bar. If required, a steady prying force on either side of the cutter bar, spaced 180° apart, can aid in removing the blade disc assembly from the spindle shaft.

C. Remove the six (6) M10 nuts connecting the spindle assembly to the cutter bar. (Figure 4-8)

D. Lightly tap a screwdriver into the two slotted notches cast into each spindle housing, positioned 180° apart. Simultaneously and with equal force, press downward on the two screwdrivers. When the sealant attaching the spindle housing to the cutter bar has been broken, **remove the entire spindle assembly from the cutter bar taking special care to keep dirt and debris out of the cutter bar.**

E. Prior to reassembling the spindle assembly onto the cutter bar (see your Bush Hog Repair Parts Catalog for the spindle assembly part number), **thoroughly clean the top face of the cutter bar casing where the spindle was originally located of all old sealant, oil and dirt.**

F. Draw a bead of oil resistant gasket sealant (Dow Corning 735 sealant recommended by manufacturer) around the perimeter of the spindle housing opening in the cutter bar casing.

G. Position the spindle assembly over the six (6) M10 bolts (ensuring that blade disc will assemble at 90° to the adjacent assembly) and join the spindle assembly to the cutter bar using the six (6) M10 nuts removed in Step C. Apply Loctite 242 thread sealant to the threads of the

Figure 4-8

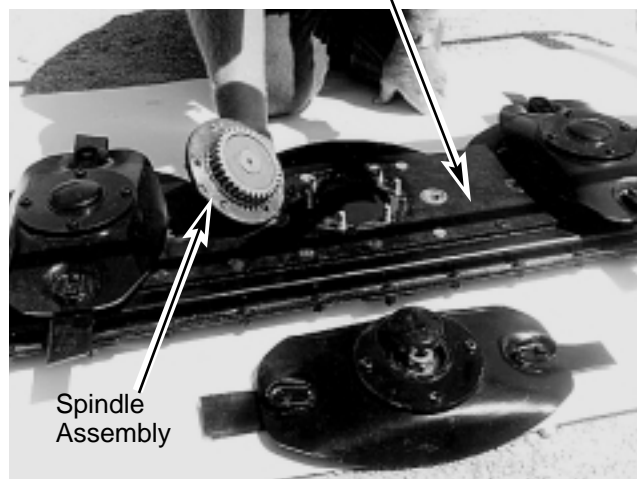

six (6) M10 bolts and torque the nuts to a value of 62.5 - 73 ft./lbs.

H. Install blade disc assembly onto the same gear assembly from which it was removed, **making sure the blades of the disc assembly being installed are exactly 90° apart from both adjacent blade disc assemblies to ensure proper timing. Tighten the retaining nut to 200 ft./lbs.** The outer gear housing assembly has the crop divider assembled to the blade disc assembly. The cap for the crop divider must be installed.

STANDARD CROP DIVIDER (Figure 4-6) Reattach the cap and cutter to the crop divider by reinstalling the four(4) capscrews through the top of crop divider and tightening securely.

OPTIONAL CROP DIVIDER (Figure 4-7) Tilt cap sideways and insert cap assembly into the top of the crop divider. Insert pointed end of threaded rod into the center hole on the end of the round output shaft. Tighten cap by turning threaded rod clockwise so cap moves up on threaded rod until it fits tight into taper of crop divider. Tighten jam nut. Snap on hub cap.

4-7 CUTTER BAR REMOVAL

- A. Lower cutter bar to rest on the ground.
- B. Remove pin (Figure 4-9) and disconnect cylinder from cylinder lug. For models with cutter bar helper spring only, disconnect helper spring assembly from curtain/beam assembly.
- C. Detach shield and curtain/beam assembly from the gearbox/cutter bar assembly. (Figure 4-9)
- D. Remove belt shield rear cover. (Figure 4-9)
- E. Loosen tension then remove the belts.
- F. Remove three bolts securing sheave to gearbox input shaft. Install bolts in adjacent holes and progressively tighten to remove sheave from tapered hub. (Figure 4-11)
- G. Remove the two bolts securing the front mounting lug (Figure 4-10). Remove front mounting lug. Detach gearbox/cutter bar assembly from the main beam/hitch frame assembly.

4-8 CUTTER BAR INSTALLATION

- A. Install gearbox into frame, securing with front mounting lug and two bolts. (Figure 4-10)
- B. Install sheave (Figure 4-11) onto gearbox input shaft and key aligning with driver sheave. Alternately tighten the three retaining bolts.
- C. Install matched set of belts (Figure 4-11) Tighten adjusting nut until belts deflect 1/2" with 10 pounds of force applied. **Rotate belt pulleys 6 complete revolutions to seat the belts into the pulleys.** Tighten adjusting nut a second time until the belts deflect 1/2 " with 10 pounds of force applied. Tighten jam nut on adjusting nut and tighten assembly pivot bolt.
- D. Install belt shield rear cover. (Figure 4-9)
- E. Attach shield and curtain/beam assembly to gearbox/cutter bar assembly. (Figure 4-9)
- F. Pin cylinder to cylinder lug. For models with cutter bar helper spring assembly, attach spring assembly to curtain/beam assembly. (Figure 4-9)

Figure 4-10

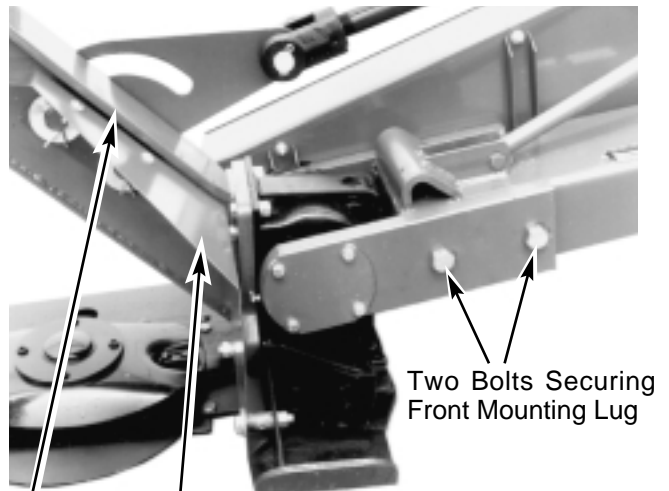

Figure 4-9

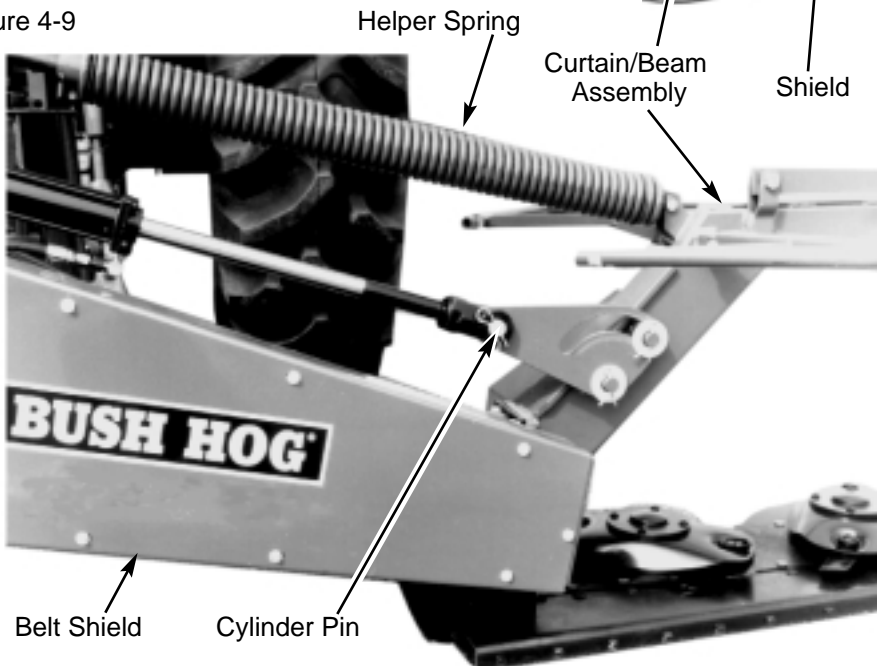
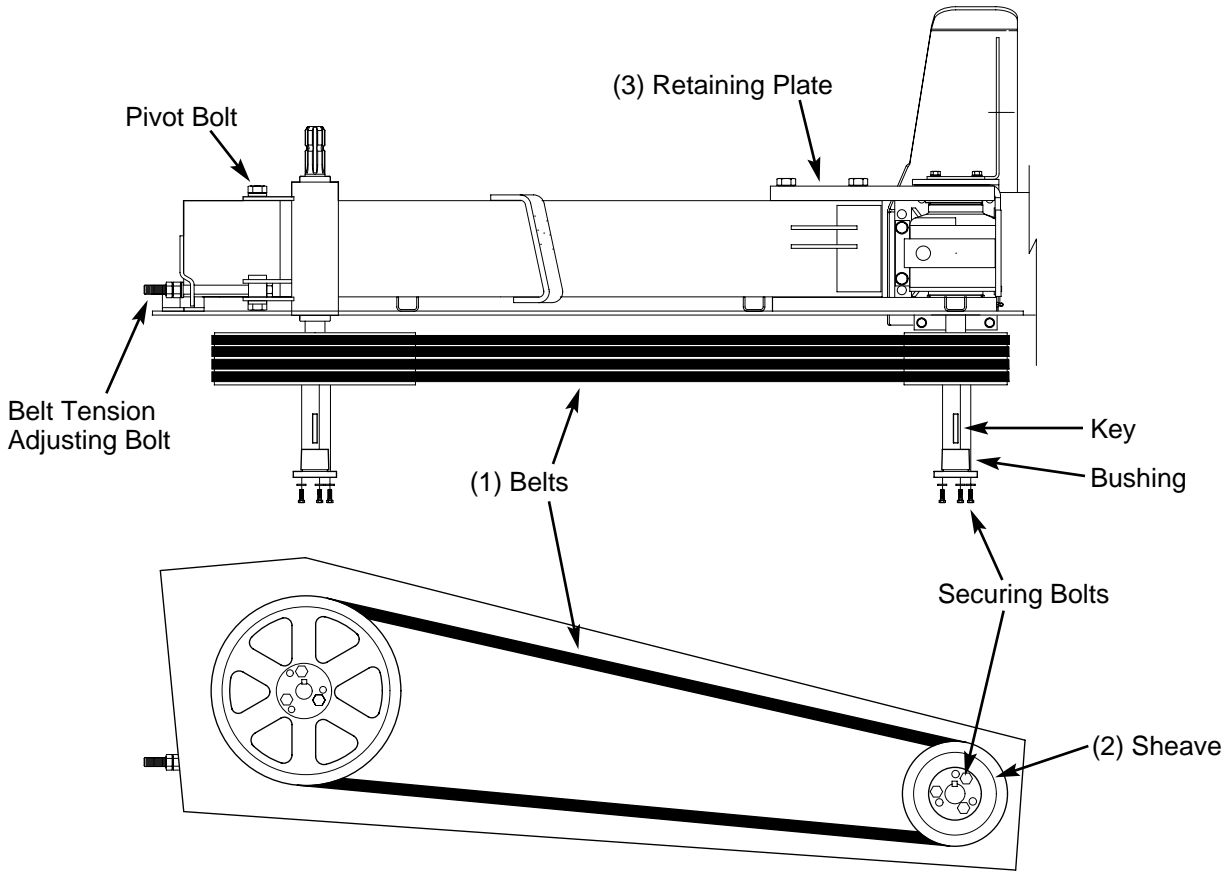

Figure 4-11



4-9 TROUBLESHOOTING

Troubleshooting procedures are listed in Table 4-1 below. If the problem cannot be solved or replacement parts are necessary, contact your authorized Bush Hog dealer. Please have ready your machine name, model number, serial number, purchase date and exact cause or description of problem.

Table 4-1 Troubleshooting

PROBLEM	PROBABLE CAUSE	REMEDY
Uneven or streaked stubble	Cylinder control valve not in "float" position.	Place valve in "float" position
	Blades dull, rounded or broken	Reverse or replace
	Low PTO speed (heavy crops)	Operate at 540 or 1000 rpm
	High PTO speed (light crops)	Operate at 540 or 1000 rpm
	Material collecting on cutter bar	Reduce cutter bar lift
	Excessive ground speed	Use lower gear
	Belt slippage	Tighten or replace belt
	Material dragging on swathboard	Remove swathboard
Stubble too long	Cutter bar tilted back too far	Tilt cutter bar forward
Vibration	Blade damaged or missing	Replace blade
	Disc damaged	Replace disc
Tapping or clicking noise	Bent blade or rock guard	Repair or replace
	Blade disc out of time	Correct timing

Figure 4-12 Cutter Bar Arrangement and Blade Rotation

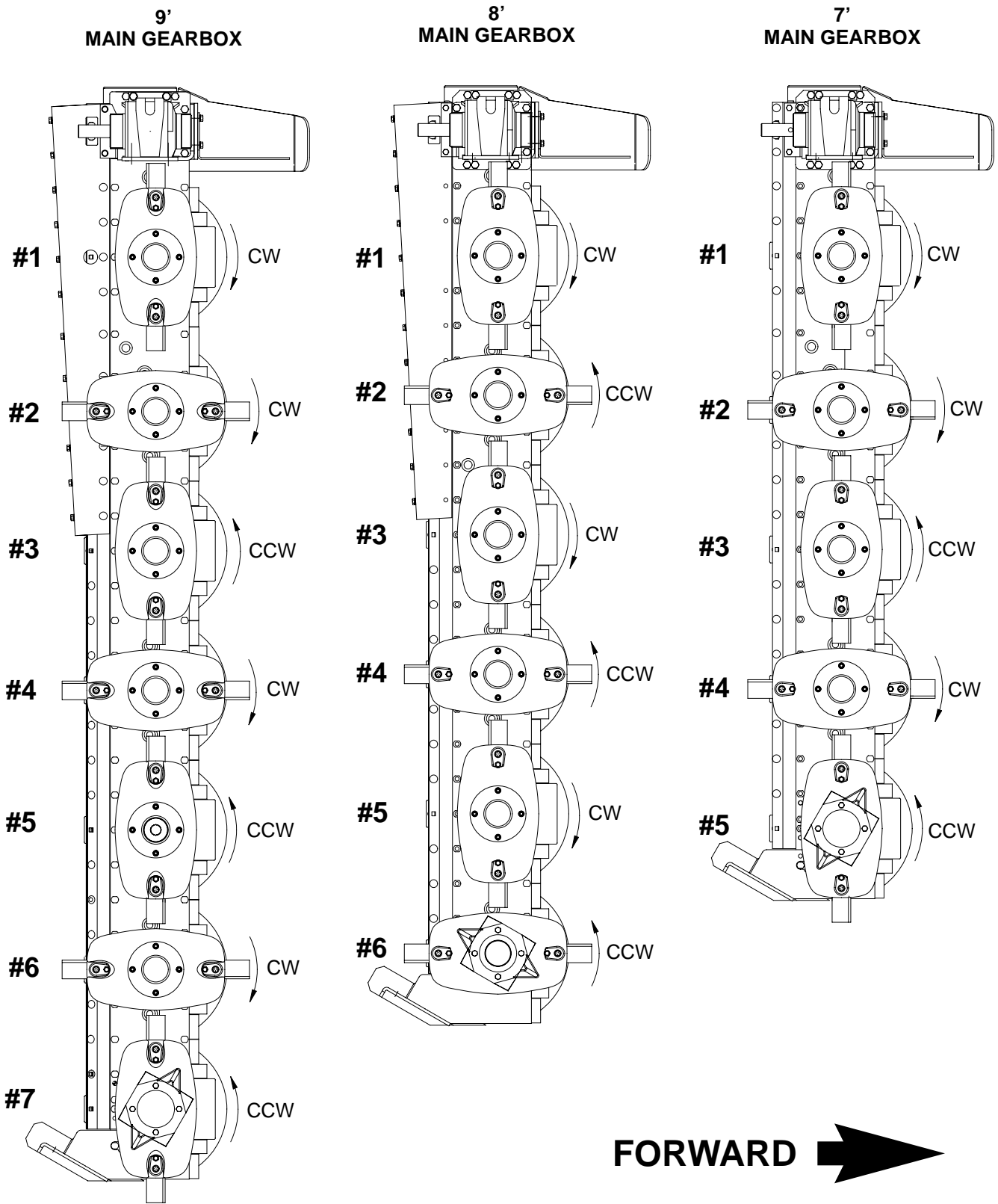

NOTE

The blades of adjacent oval discs must be 90° apart from one another as shown above to ensure proper timing.

SECTION V ASSEMBLY



THE FOLLOWING SAFETY PRECAUTIONS SHOULD BE THOROUGHLY UNDERSTOOD BEFORE ATTEMPTING MACHINE ASSEMBLY.

1. Wear protective equipment such as , but not limited to, protection for eyes, ears, feet, hands, lungs and head when assembling the equipment. Do not wear loose clothing or jewelry that may catch on equipment moving parts.
2. Do not lift heavy parts or assemblies. Use crane, jack, tackle, fork trucks, or other mechanical devices.
3. Select an area for assembly that is clean and free of any debris which might cause persons working on the assembly to trip.
4. Arrange parts to be assembled neatly in the work area and have tools or other mechanical assisting devices in easy reach.
5. Inspect all parts and assemblies thoroughly and remove any sharp edges, grease, oil, or dirt which might cause pieces to slip when handling.
6. Preview the assembly instructions in your operator's manual before proceeding further.
7. If the assembly instructions call for parts or assemblies to be blocked up, use only blocking material that is in good condition and is capable of handling the weight of the assembly to be blocked. Also insure that the blocking material is on a clean, dry surface.
8. Never put hands or any other part of body under blocked up assemblies if at all possible.
9. Always wear goggles or safety glasses when hammering, grinding or drilling metal parts.
10. If the assembly calls for welding or cutting, be sure that there are no flammable materials close at hand and the bystanders have taken necessary precautions.

AFTER COMPLETING ANY ASSEMBLY STEP, THOROUGHLY READ THE NEXT STEP IN THE ASSEMBLY INSTRUCTIONS BEFORE PROCEEDING WITH THAT STEP.

11. After completing assembly, thoroughly inspect the machine to be sure that all nuts, bolts, hydraulic fittings or any other fastened assemblies have been thoroughly tightened.
12. After completing assembly, be sure that all safety locking devices or guards are in place.
13. Before operating the machine, thoroughly read the operation section of this manual.
14. **Before operating, read the maintenance section of this manual to be sure that any parts requiring lubrication such as gearboxes are full to avoid any possible damage.**

BEFORE OPERATING THE EQUIPMENT, IF YOU HAVE ANY QUESTIONS REGARDING THE PROPER ASSEMBLY OR OPERATION, CONTACT YOUR AUTHORIZED BUSH HOG DEALER OR REPRESENTATIVE.

A. Attach hitch assembly to cutter bar assembly using 1 x 9" pin, cotter pin, 3/8 x 2" bolt, and locknut. The bolt should be installed through the welded bushing. (Figure 5-1)

B. Slide breakaway assembly over bushing on hitch mast and rotate 180 degrees to lock in place. Fasten breakaway assembly to beam using 1 x 3-3/4" bolt and locknut.

C. Pin butt end of cylinder and beam spring cushion to frame using 1 x 8-1/8" pin, 3/8 x 2" bolt, and locknut. Note that cylinder ports must be facing down.

D. Fasten opposite end of spring cushion to beam using 1/2 x 2-1/4" bolt and locknut.

E. Pin parking stand in place.

F. Attach curtain support beam to the gearbox using four 12mm x 40mm bolts and lockwashers.

G. Attach gearbox strap with 1/2 x 2" bolts, nuts and lockwashers.

H. Attach cylinder lug and dirt shield bracket to curtain support beam using two 1 x 5-1/4" pins, cotter pins and flatwashers.

I. Attach dirt shield with 1/2 x 2-1/2" bolts, nuts, flatwashers, lockwashers and spacer.

J. Attach upper end of dirt shield to dirt shield bracket with 3/8 x 1" machine screws, nuts and washers.

K. Attach rear bracket to curtain beam plate with 1/2 x 3" bolt, nut and lockwasher.

L. Fasten front and rear curtain supports to support beam using 3/8 x 2-1/4" bolts and locknuts. Do not over-tighten to allow curtain supports to pivot. Attach curtain adjustment chain between beam and frame as shown. (Figure 5-1)

M. **Remove solid plug from butt end of cylinder and install vent plug.** Plumb opposite end of cylinder as shown in Figure 5-2. Be sure that restrictor is in place on elbow.

N. Pin rod end of cylinder to cylinder lug.

O. (GHM 900 and 1900 only) Connect cutter bar helper spring to curtain support beam. Connect opposite end of helper spring to frame.

P. Lay curtain over supports. Secure using 3/8 x 1" machine screws, flatwashers, lockwashers and nuts. Use a tube clip to secure curtain to the left end

of front and rear curtain support.

Q. Fasten transport latch to curtain support beam using a 5/8 x 1-3/4" bolt and locknut. Pin opposite end in place with faspin.

R. Install curtain stop weldment flush with end of curtain support beam using one 5/8" U-bolt, lock-washer, flatwashers and nuts.

Figure 5-1 Assembly

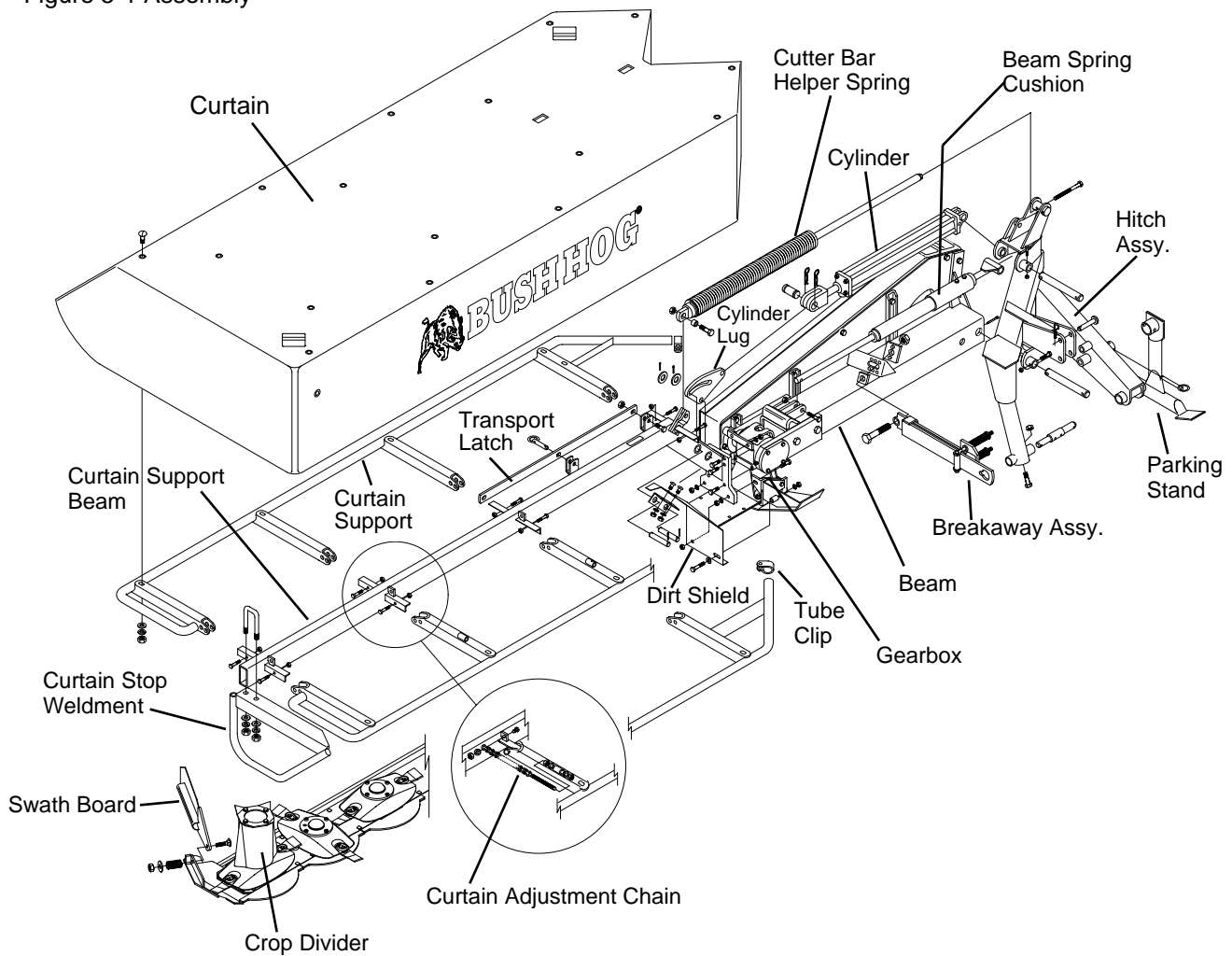
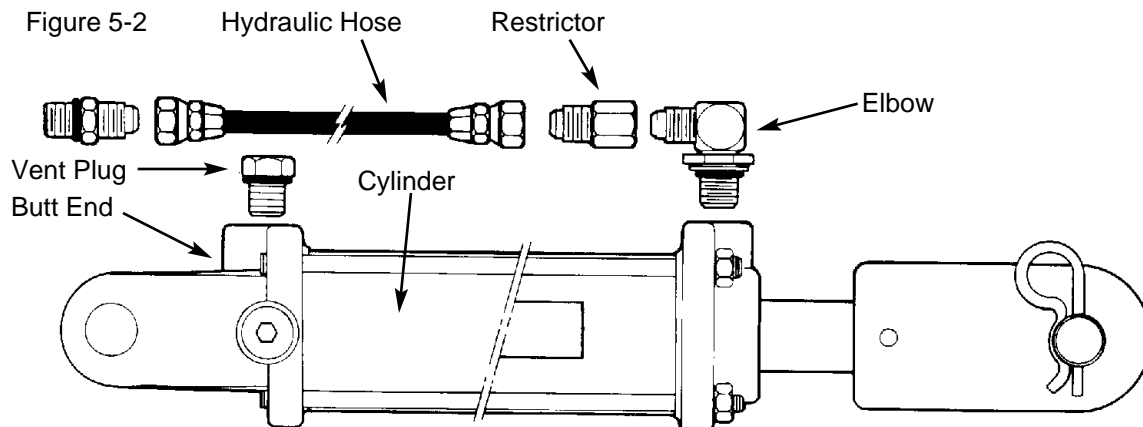

Figure 5-2



SAFETY DECALS

To promote safe operation, Bush Hog supplies safety decals on all products manufactured. Because damage can occur to safety decals either through shipment, use or reconditioning, Bush Hog will, upon request, provide safety decals for any of our products in the field at no charge. Contact your authorized Bush Hog dealer for more information.

⚠ WARNING



**TO AVOID
SERIOUS INJURY OR DEATH,**

- ★ **READ OPERATOR'S MANUAL BEFORE OPERATING & FOLLOW ALL PRECAUTIONS.**
(CONTACT DEALER FOR MANUALS.)
- ★ **KEEP SHIELDS AND GUARDS IN PLACE. KEEP CLEAR OF DRIVES AND BELTS.**
- ★ **LOWER IMPLEMENT, STOP ENGINE AND REMOVE KEY BEFORE DISMOUNTING.**
- ★ **SECURELY SUPPORT MOWER & REMOVE KEY BEFORE WORKING UNDERNEATH.**
- ★ **NO RIDERS. DO NOT OPERATE MOWER IN VICINITY OF OTHER PERSONS.**
- ★ **KNOW HOW TO STOP TRACTOR AND EQUIPMENT QUICKLY IN AN EMERGENCY.**
- ★ **CLEAR MOWING AREA OF DEBRIS.**
- ★ **ALLOW NO CHILDREN OR UNQUALIFIED PERSONS TO OPERATE EQUIPMENT.**
- ★ **BE CAREFUL ON UNEVEN TERRAIN. DECREASE SPEED WHEN TURNING.**
- ★ **DO NOT OPERATE MOWER IN TRANSPORT POSITION.**

82617

82617

⚠ WARNING

**TO AVOID
SERIOUS INJURY OR DEATH,**

- ★ **ONLY OPERATE WITH CUTTER BAR IN GROUND CONTACT POSITION.**
- ★ **STAND CLEAR IF LOWERING OR RAISING CUTTER BAR.**
- ★ **BE ALERT TO OVERHEAD OBSTRUCTIONS AND ELECTRICAL WIRES WITH CUTTER BAR IN RAISED POSITION.**
- ★ **PURGE ALL AIR FROM HYDRAULIC SYSTEM BEFORE ATTEMPTING TO RAISE OR LOWER THIS IMPLEMENT.**
- ★ **DO NOT USE HAND OR SKIN TO CHECK FOR HYDRAULIC LEAKS, USE CARDBOARD OR WOOD.**
- ★ **HIGH PRESSURE OIL LEAKS CAN PENETRATE SKIN CAUSING SERIOUS INJURY AND GANGRENE. CONSULT A PHYSICIAN IMMEDIATELY.**
- ★ **LOWER THE IMPLEMENT AND RELEASE HYDRAULIC PRESSURE BEFORE LOOSENING FITTINGS.**

86158

86158

⚠ CAUTION

BE SURE TO PURGE ALL THE AIR FROM THE HYDRAULIC SYSTEM BEFORE ATTEMPTING TO RAISE OR LOWER THIS MACHINE. REFER TO OWNERS MANUAL FOR FURTHER DETAILS.

24-6-423

24-6-423

⚠ DANGER





KEEP AWAY—CURTAIN GUARD MISSING—DO NOT OPERATE

86160

86160

⚠ CAUTION

THIS IMPLEMENT IS DESIGNED TO OPERATE AT 540 RPM MAXIMUM TRACTOR PTO SPEED. ALL DRIVE LINE SHIELDS MUST BE KEPT IN PLACE.

60873

60873

⚠ CAUTION

THIS IMPLEMENT IS DESIGNED TO OPERATE AT 1000 RPM MAXIMUM TRACTOR PTO SPEED. ALL DRIVE LINE SHIELDS MUST BE KEPT IN PLACE.

60874

60874

⚠ WARNING



TO AVOID SERIOUS INJURY OR DEATH:

- ★ LOCK CUTTER BAR UP FOR TRANSPORT
- ★ INSTALL TRANSPORT LOCK PINS.
- ★ READ OPERATOR'S MANUAL FOR INSTRUCTIONS.

86159

⚠ DANGER



KEEP AWAY—ROTATING BLADES

SERIOUS INJURY OR DEATH CAN RESULT FROM THROWN OBJECTS OR BLADE CONTACT.

- ★ DO NOT STAND ON OR NEAR MACHINE WHEN IN OPERATION.
- ★ DO NOT OPERATE WITH CURTAIN GUARD REMOVED.
- ★ DO NOT OPERATE WITHOUT CURTAIN GUARD IN GOOD CONDITION OR REPAIR.
- ★ ROPS (ROLLOVER PROTECTIVE SYSTEM) AND SEAT BELT EQUIPPED TRACTOR IS RECOMMENDED FOR OPERATOR USE IN ALL MOWING OPERATIONS.

86118

⚠ DANGER



ROTATING DRIVELINE CONTACT CAN CAUSE DEATH

KEEP AWAY!

DO NOT OPERATE WITHOUT —

- ALL DRIVELINE, TRACTOR AND EQUIPMENT SHIELDS IN PLACE
- DRIVELINES SECURELY ATTACHED AT BOTH ENDS
- DRIVELINE SHIELDS THAT TURN FREELY ON DRIVELINE

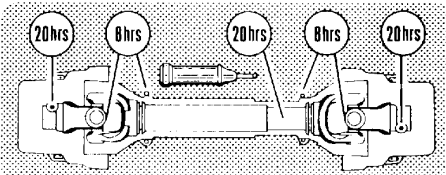

78608

⚠ DANGER



KEEP AWAY!

SHIELD MISSING FROM THIS AREA

TO AVOID SERIOUS INJURY OR DEATH, DO NOT OPERATE WITHOUT THIS AND ALL OTHER SHIELDS IN PLACE AND IN GOOD CONDITION.

50012616

50012616

⚠ DANGER



SHIELD MISSING

DO NOT OPERATE

78786

⚠ WARNING

ROTATING DRIVE PARTS BENEATH

- ENTANGLEMENT WITH ROTATING DRIVE PARTS CAN CAUSE INJURY OR DEATH.
- DO NOT OPERATE WITHOUT THIS AND ALL OTHER SHIELDS IN PLACE AND IN GOOD CONDITION.

50012615

50012615

TORQUE SPECIFICATIONS

Proper torque for American fasteners used on Bush Hog equipment.
Recommended Torque in Foot Pounds (Newton Meters).*

AMERICAN Bolt Head Markings

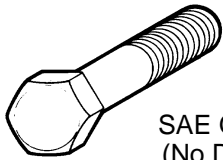

SAE Grade 2
(No Dashes)

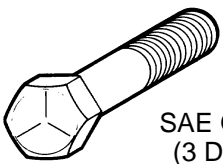

SAE Grade 5
(3 Dashes)

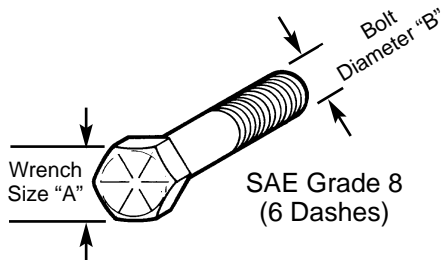

SAE Grade 8
(6 Dashes)

WRENCH SIZE (IN.) "A"	BOLT DIAMETER (IN.) "B" AND THREAD SIZE	SAE GRADE 2	SAE GRADE 5	SAE GRADE 8
7/16	1/4 - 20 UNC	6 (7)	8 (11)	12 (16)
7/16	1/4 - 28 UNF	6 (8)	10 (13)	14 (18)
1/2	5/16 - 18 UNC	11 (15)	17 (23)	25 (33)
1/2	5/16 - 24 UNF	13 (17)	19 (26)	27 (37)
9/16	3/8 - 16 UNC	20 (27)	31 (42)	44 (60)
9/16	3/8 - 24 UNF	23 (31)	35 (47)	49 (66)
5/8	7/16 - 14 UNC	32 (43)	49 (66)	70 (95)
5/8	7/16 - 20 UNF	36 (49)	55 (75)	78 (106)
3/4	1/2 - 13 UNC	49 (66)	76 (103)	106 (144)
3/4	1/2 - 20 UNF	55 (75)	85 (115)	120 (163)
7/8	9/16 - 12 UNC	70 (95)	109 (148)	153 (207)
7/8	9/16 - 18 UNF	79 (107)	122 (165)	172 (233)
15/16	5/8 - 11 UNC	97 (131)	150 (203)	212 (287)
15/16	5/8 - 18 UNF	110 (149)	170 (230)	240 (325)
1-1/8	3/4 - 10 UNC	144 (195)	266 (360)	376 (509)
1-1/8	3/4 - 16 UNF	192 (260)	297 (402)	420 (569)
1-5/16	7/8 - 9 UNC	166 (225)	430 (583)	606 (821)
1-5/16	7/8 - 14 UNF	184 (249)	474 (642)	668 (905)
1-1/2	1 - 8 UNC	250 (339)	644 (873)	909 (1232)
1-1/2	1 - 12 UNF	274 (371)	705 (955)	995 (1348)
1-1/2	1 - 14 UNF	280 (379)	721 (977)	1019 (1381)
1-11/16	1-1/8 - 7 UNC	354 (480)	795 (1077)	1288(1745)
1-11/16	1-1/8 - 12 UNF	397 (538)	890 (1206)	1444 (1957)
1-7/8	1-1/4 - 7 UNC	500 (678)	1120 (1518)	1817 (2462)
1-7/8	1-1/4 - 12 UNF	553 (749)	1241 (1682)	2013 (2728)
2-1/16	1-3/8 - 6 UNC	655 (887)	1470 (1992)	2382 (3228)
2-1/16	1-3/8 - 12 UNF	746 (1011)	1672 (2266)	2712 (3675)
2-1/4	1-1/2 - 6 UNC	870 (1179)	1950 (2642)	3161 (4283)
2-1/4	1-1/2 - 12 UNF	979 (1327)	2194 (2973)	3557 (4820)

Proper torque for metric fasteners used on Bush Hog equipment.
Recommended torque in foot pounds (newton Meters).*

METRIC

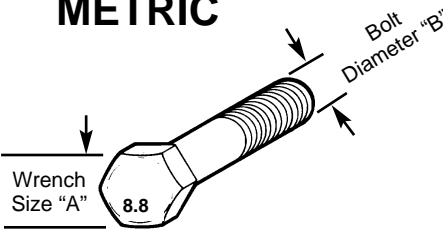

Numbers appearing on bolt heads indicate ASTM class.

WRENCH SIZE (mm) "A"	BOLT DIA. (mm) "B"	ASTM 4.6	ASTM 8.8	ASTM 9.8	ASTM 10.9
8	5	1.8 (2.4)		5.1 (6.9)	6.5 (8.8)
10	6	3 (4)		8.7 (12)	11.1 (15)
13	8	7.3 (10)		21.1 (29)	27 (37)
16	10	14.5 (20)		42 (57)	53 (72)
18	12	25 (34)	74 (100)	73 (99)	93 (126)
21	14	40 (54)	118 (160)	116 (157)	148 (201)
24	16	62 (84)	167 (226)	181 (245)	230 (312)
30	20	122 (165)	325 (440)		449 (608)
33	22		443 (600)		611 (828)
36	24	211 (286)	563 (763)		778 (1054)
41	27		821 (1112)		1138 (1542)
46	30	418 (566)	1119 (1516)		1547 (2096)

*Use 75% of the specified torque value for plated fasteners. Use 85% of the specified torque values for lubricated fasteners.



BUSH HOG[®], L.L.C.

P.O. Box 1039 • Selma, AL 36702-1039

Telephone (334) 874-2700 • www.bushhog.com